

SIM 229

Cytoplasmic and periplasmic expression of a highly basic protein, human interleukin 4, in *Escherichia coli*

Daniel Lundell¹, Robert Greenberg¹, Yair Alroy², Russell Condon², James D. Fossetta¹, Keith Gewain*, Rob Kastelein⁴, Charles A. Lunn¹, Richard Reim¹, Chandravadan Shah³, Anita van Kimmenade⁴ and Satwant K. Narula¹

1. *Biotechnology - Molecular Biology*; 2. *Biotechnology - Fermentation Development*; 3. *Biotechnology - Assays*; 4. *The DNAX Research Institute, Palo Alto, CA 94304, U.S.A.*

Received 17 March 1989

Revision received 7 May 1989

Accepted 24 May 1989

Key words: IL-4; *E. coli*; Expression; Plasmid constructions; Secretion

SUMMARY

Human IL-4 (hIL-4) has been cloned from a human T cell line based on its homology to the murine IL-4 cDNA sequence [36]. We have compared cytoplasmic and extra-cytoplasmic expression of this basic protein in *Escherichia coli* using various combinations of promoters, replicons and host strains. Strains producing a cytoplasmic product were most successful at heterologous protein expression, producing up to 500 mg/l of an inactive aggregated form of the protein. The biological activity of the protein could be restored by refolding the protein with guanidine hydrochloride and glutathione giving a specific activity identical to that of IL-4 derived from CHO cell lines stably transformed with an hIL-4 expression plasmid. Strains designed to secrete human IL-4 into the periplasmic space produced far less protein (approximately 5 mg/l). However, a significant fraction of this protein was detected in the culture medium. This fraction appeared to be soluble after ultracentrifugation, and demonstrated high specific activity without refolding. Leakage of heterologous protein into the culture medium may be a viable way to recover biologically active products without relying on the denaturation and refolding in vitro that can, at times, yield incorrectly folded gene product.

INTRODUCTION

Originally described as B-cell stimulatory factor I (BSF-I), Human IL-4 is a highly species-specific glycoprotein [25]. It affects the activities of several different haemopoietic cells such as B cells [8], T

* Present address: Merck Sharp & Dohme, Research Laboratories, P.O. Box 200, Rahway, NJ 07065-0900
Correspondence: Satwant K. Narula, Schering Corporation, 60 Orange Street, Bloomfield, NJ 07003, U.S.A.

cells and mast cells [24], enhances IL-2 dependent T-cell proliferation [36], induces the expression of class II MHC antigens on resting B cells, bone marrow derived macrophages and activated thymocytes [37,7]. It has also been shown to induce the IgE receptor, FcεRII/CD23 [15]. The hIL-4 receptor has been found on both haemopoietic and non-haemopoietic cell lines [5,20]. The mature protein consists of 129 amino acids and exhibits an apparent molecular weight (including glycosylation) of 20 000. The mature protein contains six cysteine residues. Reduction of the molecule causes loss in biological activity indicating that at least some of the cysteine residues are involved in the formation of disulfide bonds that are integral to its functional activity (personal communication, P. Trotta, Schering Corp., Bloomfield, NJ).

We have investigated the production of hIL-4 in *E. coli*. Cytoplasmic expression of hIL-4 results in high levels of insoluble product. This product can be refolded by conventional means to yield a protein with high specific biological activity; however, there is preliminary evidence that the refolded material is heterogenous. We have contrasted cytoplasmic expression with a secretory expression system. This system processes the signal sequence giving a product with the correct amino terminus but also yields insoluble cell-associated (periplasmic) protein. Surprisingly, a significant percent of the processed protein 'leaks' from the cell as a soluble, active molecule. We propose the isolation of this leaked material as a viable alternative to refolding insoluble hIL-4.

MATERIALS AND METHODS

Host strains

E. coli 294 (*end*⁻, *hsdR*, *thi*, *pro*) has been previously described [3]. Other host strains used in this study were W3110 (*F*⁻, *hsdR*, *HsdM*⁺) [6] DH-1 [*F*⁻, *recA1*, *endA1*, *gyrA96*, *thi-1*, *hsdR17*(*r_k*⁻, *m_k*⁺), *supE44*, *recA1,λ*⁻] [22] and AB1899 (*thr-1*, *leuB6*, *thi-1*, *argE3*, *hisG4*, *proA2*, *lon-1*, *lacY1*, *galK2*, *mtl-1*, *xyl-5*, *ara-14*, *strA31*, *tsx-33*, *λ*⁻, *supE44*) [14].

Plasmids

pTACRBS, a high copy number vector carrying a TAC promoter upstream of the lac ribosome binding site and, in addition, a synthetic consensus ribosome binding site, has been described previously [26]. pKG-2 [11] is a derivative of pVU208, a thermoinducible runaway replication plasmid [12]. pKG-86 is a derivative of pKG-2. The 959 bp fragment of pBR325 [29] carrying the chloramphenicol resistance gene was isolated following digestion with *Bam*I, Klenow fill in, and digestion with *Aat*II. This region was then inserted between the *Aat*II and *Sca*I sites of pKG-2, resulting in the chloramphenicol and tetracycline resistant thermoinducible high copy number plasmid, pKG-86.

Construction of pKGT189-12

We initially sought to determine the solubility of a native IL-4 molecule produced in the cytoplasm of *E. coli*. The isolation of the human interleukin-4 cDNA in the expression plasmid, pcD-hIL-4, has been described [36]. In order to construct the mature hIL-4 coding sequence for expression of the protein in *E. coli*, pcD-hIL-4 was restricted with *Eco*RV and *Bam*HI. The 550 bp fragment carrying all but the first 12 base pairs of the IL-4 coding region was cloned between the *Eco*RV and *Bam*HI sites in pBR322, resulting in the plasmid, pRGT651-3, as shown in Fig. 1. To complete the 5' end of the coding region, the synthetic oligonucleotides shown in Fig. 1 were cloned between the *Hin*dIII and *Eco*RV sites in pRGT651-3, resulting in the plasmid, pRGT662-3.

In order to express hIL-4 in *E. coli*, pRGT662-3 was restricted with *Sac*I and the 3' overhang was removed by the action of T4 DNA polymerase. The plasmid was then restricted with *Sal*I. The approximately 825 bp fragment carrying the mature hIL-4 coding region was then cloned behind the TAC promoter in the plasmid pTACRBS [26] as follows: pTACRBS was digested with *Sac*I. The 3' overhang was removed with T4 DNA polymerase, and the plasmid was then digested with *Sal*I. The large fragment carrying the TAC promoter, ampicillin resistance gene and high copy number ori was isolated and ligated to the 825 bp hIL-4 fragment. The liga-

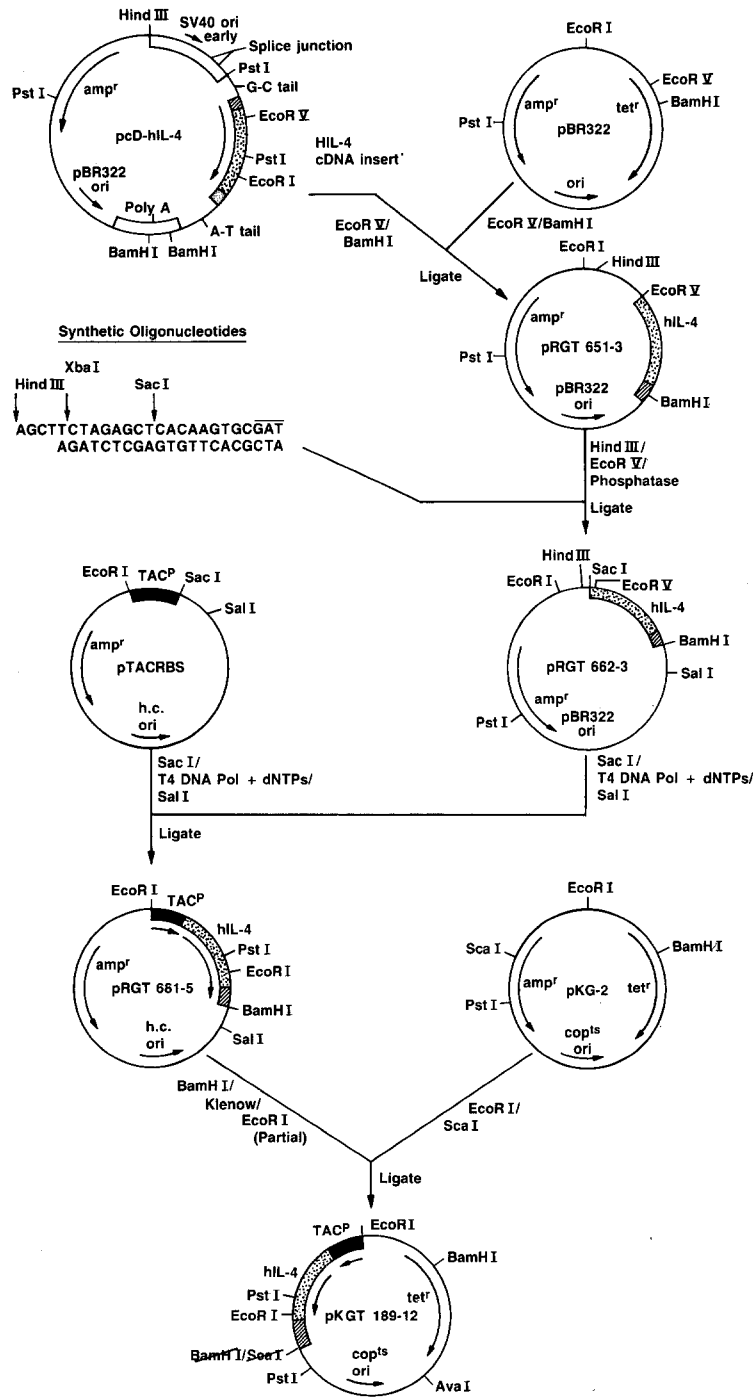

Fig. 1. Construction of the cytoplasmic hIL-4 expression plasmid, pKGT189-12: pKGT189-12 was constructed as shown. Details of the construction scheme are given in the text. Shown on the oligonucleotides is an overscore, indicating the 5' half of an *EcoRV* restriction site, and arrows, indicating the cleavage sites of the other restriction endonuclease sites present. The diagram is not drawn to scale. Abbreviations as used: hIL-4, human IL-4 gene; TAC, TAC promoter; amp^r, ampicillin resistance marker; tet^r, tetracycline resistance marker; h.c. ori; high copy number origin of replication, cop^{ls} ori; origin of replication for pVU208.

tion was used to transform *E. coli* 294. One of the resulting transformants, known as pRGT681-5 is shown in Fig. 1.

A thermoinducible high copy number, tetracycline resistant hIL-4 expression vector was next constructed from pRGT681-5. pRGT681-5 was restricted with *Bam*HI and the 5' overhang filled in by the action of Klenow polymerase. The vector was subsequently digested with *Eco*RI and the approximately 800 bp fragment carrying the TAC promoter and the hIL-4 coding region was ligated to the large *Eco*RI-*Sca*I fragment of pKG-2 carrying the Cop^{ts} origin of replication and the gene encoding tetracycline resistance. Following transformation of *E. coli* 294, one of the resulting transformants was pKGT189-12, as shown in Fig. 1.

Construction of pKGT269-2

Due to the insolubility and low refolding yield of hIL-4 expressed in the bacterial cytoplasm, we constructed expression vectors capable of secreting mature hIL-4 into the *E. coli* periplasmic space. The *E. coli* secretory expression vector pINIIIompA2 [10] was subjected to site specific mutagenesis as previously described [38], converting the 3' end of the ompA signal peptide coding region into a *Hind*III recognition site. This resulted in the secretory vector known as pompH3, as shown in Fig. 2. The *Eco*RV-*Bam*HI fragment carrying all but the first 12 bp of the mature hIL-4 coding region was isolated from pcD-hIL-4 as described above. A region of synthetic DNA encoding the first four amino acids of mature hIL-4 and carrying the four bp *Hind*III overhang was synthesized (as shown in Fig. 1). The vector pompH3 was digested with *Hind*III and *Bam*HI, removing the polylinker. The vector was then simultaneously ligated to both the *Eco*RV-*Bam*HI hIL-4 fragment and the synthetic DNA fragment. One of the resulting hIL-4 expression plasmids, known as pAH3, is shown in Fig. 2.

In an attempt to increase the expression level, hIL-4 was next cloned into a thermoinducible high-copy number vector, viz., pKG-2. The plasmid pAH3 was digested with *Aat*II and *Ava*I and the large fragment carrying the hIL-4 coding region was ligated to the *Aat*II-*Ava*I fragment of pKG-86

carrying the thermoinducible origin of replication and the gene encoding chloramphenicol resistance. The ligation mixture was used to transform *E. coli* 294. One of the resulting clones carried the chloramphenicol resistant, thermoinducible high copy number hIL-4 expression plasmid pKGT269-2.

DNA synthesis

DNA synthesis was performed on a Applied Biosystems Model 380 A DNA synthesizer.

Enzymes

All restriction enzymes, T4 DNA ligase and Klenow fragment of DNA polymerase I were obtained from New England Biolabs and were used in accordance with the manufacturer's recommendations.

Growth of cells

Cells with temperature inducible plasmids were grown at 30°C in baffled shake flasks or in 10 liter fermenters controlled for pH (7.0) and oxygen saturation (50%) prior to induction. For all fermentations modified GC medium was used. This media consists of 30 g/l casamino acids, 20 g/l yeast extract, 5 g/l KH₂PO₄ pH 7.0; with 20 ml/l each of 80% glycerol and 200 mM MgSO₄ solution were added after autoclaving.

Preparation of samples for analysis

Cells were harvested by centrifugation and resuspended in 20 mM sodium phosphate, 150 mM NaCl pH 7.4 (PBS) to an optical density of 30 at 660 nm. Cells were broken on ice with a Heat Systems-Ultrasonic Inc. sonicator until the optical density at 660 nm was 3 or lower. Insoluble material was recovered by centrifugation at 4°C and 7 000 × g for 10 min. This fraction contained all of the IL-4 in most strains examined. From secretory strains, the growth medium was saved. The medium was treated with 5% trichloroacetic (TCA) acid (w/v) and the precipitate recovered.

Electrophoretic analysis

For SDS polyacrylamide gel electrophoresis [19] broken cell or TCA pellets (see above) were resus-

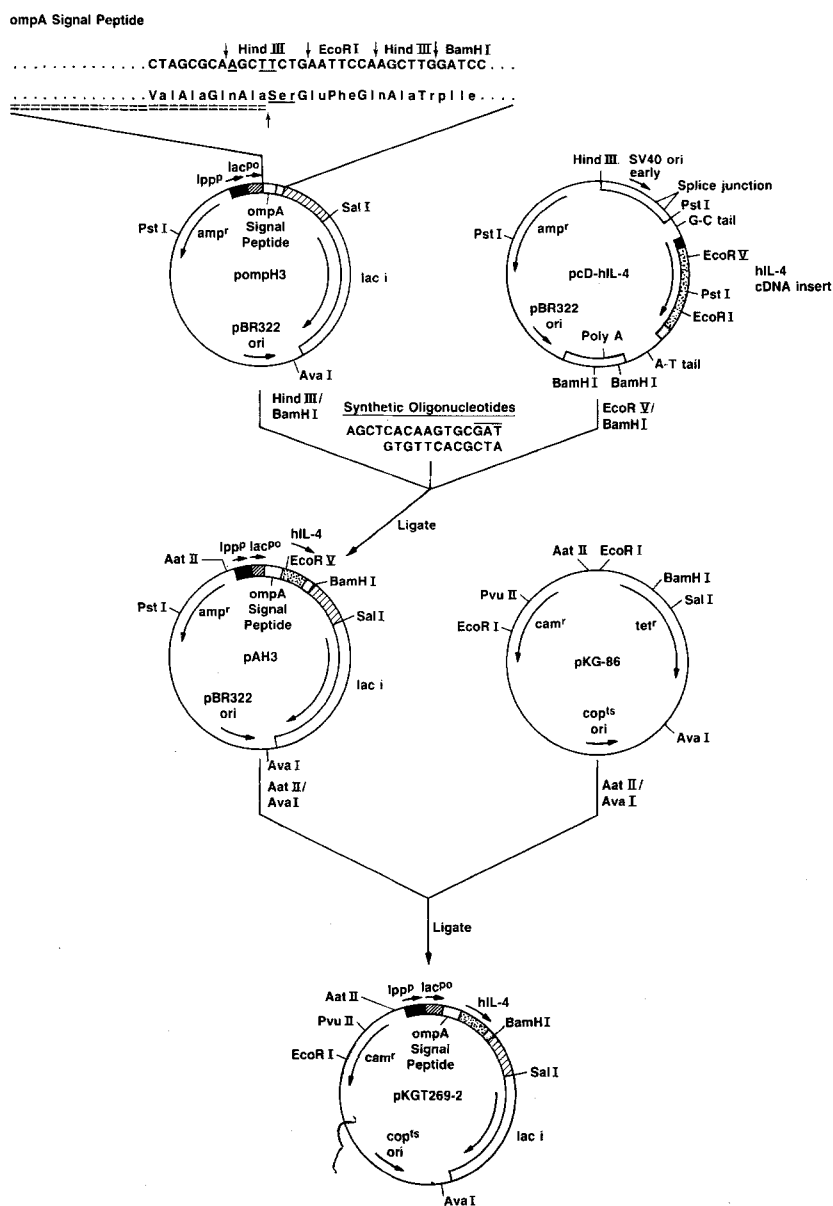

Fig. 2. Construction of the periplasmic human IL-4 expression plasmid, pKGT269-2: pKGT269-2 was constructed as shown. Details of the construction schema are given in the text. The double underline indicates the signal peptide coding region. Underscores in expansion of pompH3 indicates changes made in the construction of pompH3 from pINIIOmpA [10]. The diagram is not drawn to scale. Abbreviations as used: hIL-4, human IL-4 gene; OmpA, ompA signal peptide; lpp^P, bacterial major lipoprotein promoter; lac^{po} promoter/operator; amp^r, ampicillin resistance marker; tet^r, tetracycline resistance marker; cam^r, chloramphenicol resistance marker; cop^{ts} ori, origin of replication from pVU208.

pended to an optical density of 30 at 660 nm based on the original culture density in 10 mM Tris-HCl pH 8, 1% SDS, 10% sucrose, 1% mercaptoethanol,

0.001% bromophenol blue and heated at 95°C for 10 min. For Coomassie blue stained gels 20 μ l of sample was loaded per lane of a 15% acryla-

mid-0.4% bisacrylamide gel. Western blots [34] were performed on SDS gels transferred to nitrocellulose paper. Filters were incubated with 10 mM Tris-HCl pH 8, 150 mM NaCl, 0.05% Tween 20 and 0.5% bovine serum albumin containing a rabbit polyclonal antibody raised to SDS denatured IL-4. A goat anti-rabbit alkaline phosphatase conjugate (Jackson Immuno Research Laboratories, West Grove, PA) was used for the second antibody reaction. Color development was performed with Promega-Biotec 'Problot' reagents as described by the manufacturer. Scanning of Coomassie blue stained gels was done with an LKB Ultrascan XL Laser Densitometer.

Refolding studies

Insoluble material after sonication was dissolved in 6 M guanidine hydrochloride, 20 mM Tris-HCl pH 8, 10 mM glutathione to an optical density equivalent to 100 at 660 nm (based on the original cell density). Insoluble material was removed by centrifugation. The supernatant was then diluted

100 fold in 1 M guanidine-HCl, 20 mM Tris-HCl pH 8, 2.5 mM glutathione and 0.5 mM oxidized glutathione. After holding at 4°C overnight, the sample was dialyzed against 20 mM Tris-HCl pH 8 at 4°C. Insoluble material was removed and the supernatant analyzed for biological activity. Van Kimmenade et al. [35], described a similar procedure for refolding hIL-4. For sonicate pellets from secretory expression strains no reduced or oxidized glutathione was used at any time.

Bioassays

The biological activity of hIL-4 was determined with a peripheral blood lymphocyte cell proliferation assay [36].

RESULTS

Human IL-4 expression in the cytoplasm of *E. coli*

We have examined the production of hIL-4 from two different plasmid constructions, pRGT681-5

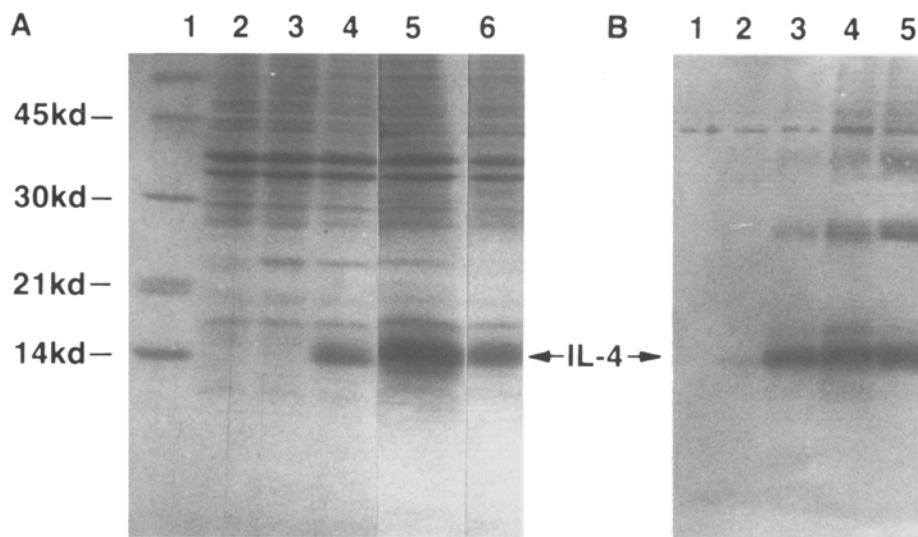

Fig. 3. Effect of temperature on expression of hIL-4 in the cytoplasm. pKGT189-12/*E. coli* 294 was grown in modified GC medium at 30°C. Upon reaching an optical density of 1 at 660 nm, equal aliquots were removed and fermentation continued at 30°C, 34°C, 38°C and 42°C. One flask was kept at 30°C. pKGT681-5/*E. coli* 294 was fermented in modified GC medium at 37°C throughout the experiment. Cells were harvested, lysed by sonication and the insoluble fraction analyzed by SDS polyacrylamide gel electrophoresis. The gels were then stained for total protein with Coomassie Blue (Panel A) or stained immunologically for IL-4 protein (Panel B). Panel A, lane 1, molecular weight standards (indicated as kilodaltons to left); lanes 2–5 pKGT189-12/*E. coli* 294 grown at 30°C, 34°C, 38°C and 42°C, respectively; lane 6, pRGT681-5/*E. coli* 294 at 37°C. Panel B, lanes 1–4 pKGT189-12/*E. coli* 294 at 30°C, 34°C, 38°C and 42°C; lane 5, pRGT681-5/*E. coli* 294 at 37°C. Migration position of hIL-4 (arrow) is shown.

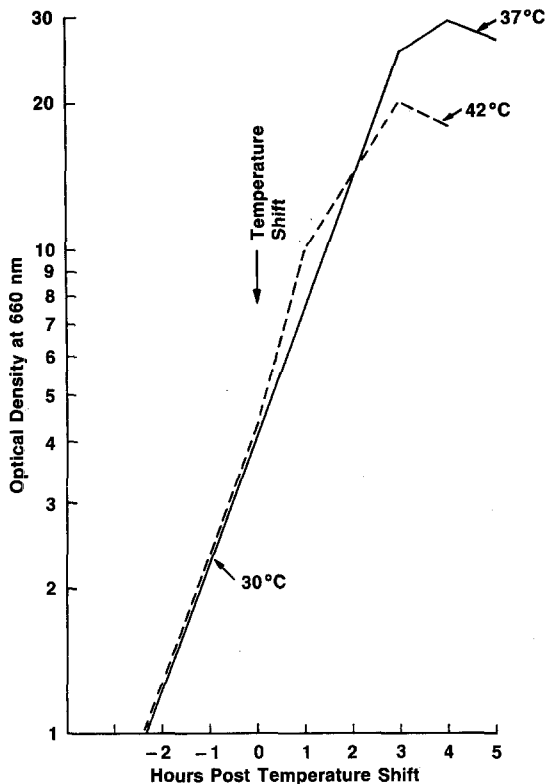

Fig. 4. Effect of temperature on growth kinetics of pKGT189-12/*E. coli* 294: Matched cultures of pKGT189-12/*E. coli* 294 were grown at 30°C in modified GC medium as described. Upon reaching an optical density of 4 at 660 nm the fermentation temperatures were shifted to 37°C to 42°C, and fermentations continued. Cell densities were measured spectrophotometrically.

and pKGT189-12. The production of IL-4 from each was comparable if pKGT189-12 was grown at 38–40°C. Therefore, the majority of our work was with this plasmid because production could be regulated by temperature.

IL-4 expression was estimated by Coomassie stained SDS-PAGE and western blot of pKGT189-12/*E. coli* 294 at various temperatures (Fig. 3). A large increase in expression level was noted at growth temperatures of 34°C, 38°C and 42°C. Total production at 42°C was typically about 5% of total protein as estimated by gel scanning. Production of hIL-4 from pRGT681-5/*E. coli* 294 at 37°C is shown in panel A, lane 6.

Expression of IL-4 by pKGT189-12/*E. coli* 294

was further examined at 37°C versus 42° in 10-l fermentors controlled for pH (7.0) and dissolved oxygen (50% saturation). At an optical density of 4 at 660 nm, the cultures were shifted from 30°C to 37°C or 42°C. The 42°C culture reached an optical density of about 18–20 at 660 nm, while the 37°C culture reached an optical density of 30 at 660 nm (Fig. 4). Since an uninduced culture (maintained at 30°C) also reached an optical density of 30, induction of hIL-4 production, per se, has no deleterious effects on cell growth. The lower growth potential at 42°C may be due to effects of temperature and increased plasmid copy number rather than the hIL-4 production. The kinetics of expression of hIL-4 from each fermentation are shown in Fig. 5.

Effect of host backgrounds on hIL-4 expression

Expression of hIL-4 from pKGT189-12 varied widely depending on the strain of *E. coli* (Fig. 6). Strains 294 and W3110 resulted in high and equivalent expression while DH1 and AB1899 yielded considerably lower production. The reasons for these differences are presently unknown.

Solubility of IL-4

The hIL-4 expressed in *E. coli* from either pKGT189-12 or pRGT681-5 plasmid at 23–42°C was totally insoluble, i.e., less than 0.1% of total hIL-4 was found in the supernatant of sonicated cells after centrifugation at $200\,000 \times g$ for 30 min. Microscopic examination of cells induced at 42°C, where expression is highest, surprisingly showed no evidence of polar inclusion bodies. Inclusion bodies at the bacterial poles have been seen with other proteins expressed at about 5% of total protein, e.g., prochymosin [32,33]. Electron micrographs (Fig. 7) taken of pKGT189-12/*E. coli* 294 before and after induction at 42°C again did not show evidence of polar inclusion bodies, but did show nondescript electron dense regions at numerous sites along the inner surface of the cytoplasmic membrane.

Refolding studies

Since the hIL-4 expressed in *E. coli* was insoluble, it was solubilized prior to assay. Biological activity was evaluated with a lymphocyte proliferation as-

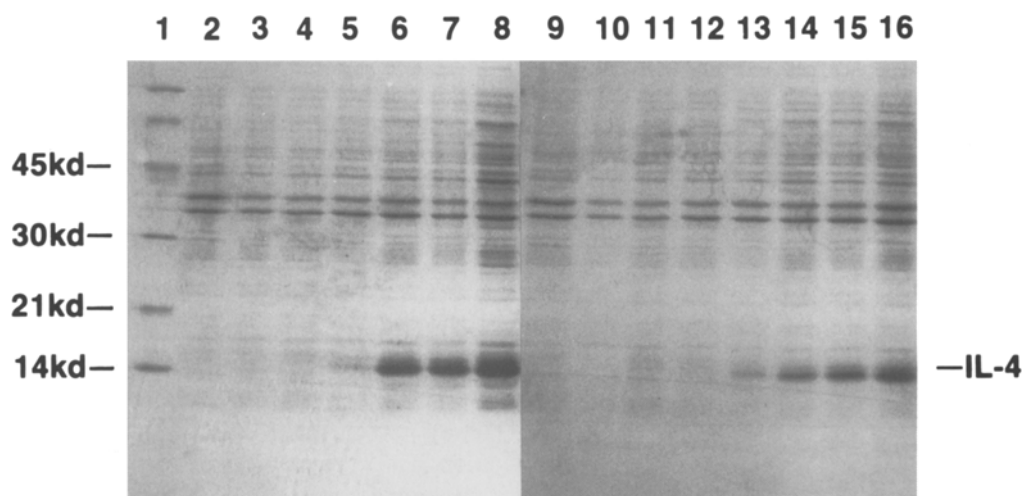

Fig. 5. Effect of temperature on induction kinetics of human IL-4 in pKGT189-12/*E. coli* 294: Aliquots of fermentations described in Figure 3 were removed at the designated times. Cells were harvested, lysed by sonication and the insoluble fraction analyzed by SDS polyacrylamide gel electrophoresis. The gels were then stained for total protein using Coomassie Brilliant Blue. Lane 1, molecular weight standards (indicated as kilodaltons to left); lanes 2 and 9, pKG2/*E. coli* 294 negative control; lanes 3-8, pKGT189-12/*E. coli* 294 - 1, 0, 1, 2, 3 and 4 h after shifting from 30°C to 42°C; lanes 10-16, pKGT189-12/*E. coli* 294 - 1, 0, 1, 2, 3, 4, 9 and 5 h after shifting from 30°C to 37°C. The migration position of hIL-4 is marked.

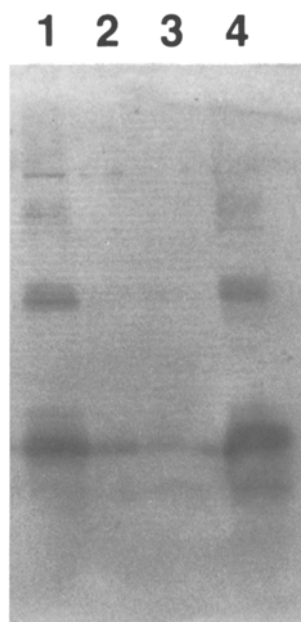

Fig. 6. Effect of bacterial host strains on IL-4 expression from pKGT189-12:*E. coli* strains 294 (lane 1); DH-1 (lane 2); AB1899 (lane 3); and W3110 (lane 4) were transformed with pKGT189-12 and grown as described. Upon reaching an optical density of 1 at 660 nm, cultures were shifted to 40°C, and fermentations continued for 3 h. Cells were harvested, lysed by sonication and the insoluble fraction analyzed by SDS polyacrylamide gel electrophoresis. The gels were then stained immunologically for hIL-4.

say and SDS lysates of pKGT189-12/294 induced at various temperatures versus time were examined (Fig. 8). Cell pellets were resuspended to an optical density of 30 at 660 nm (based on original cell density) and lysed with SDS similarly to the procedure used for solubilizing sonicate pellets (without the addition of bromophenol blue) as described in Materials and Methods. The lysate was diluted 1:5; in bioassay medium. It is clear that bioactivity increased with time of induction as does hIL-4 expression (see above). The specific activity of SDS solubilized hIL-4 was 730 ± 300 u/ μ g. This is considerably lower than that for native hIL-4 of $\sim 25\,000$ u/ μ g [35].

If 6 M guanidine-hydrochloride at pH 7.5 was used for solubilization instead of SDS, specific activity increased about five-fold. With this available information, we devised a simple refolding scheme based on common protocols which yielded soluble hIL-4 from the insoluble pellet fraction.

Human IL-4 expression in the periplasm

We characterized the production of hIL-4 from two strains which secreted hIL-4 into the periplasm

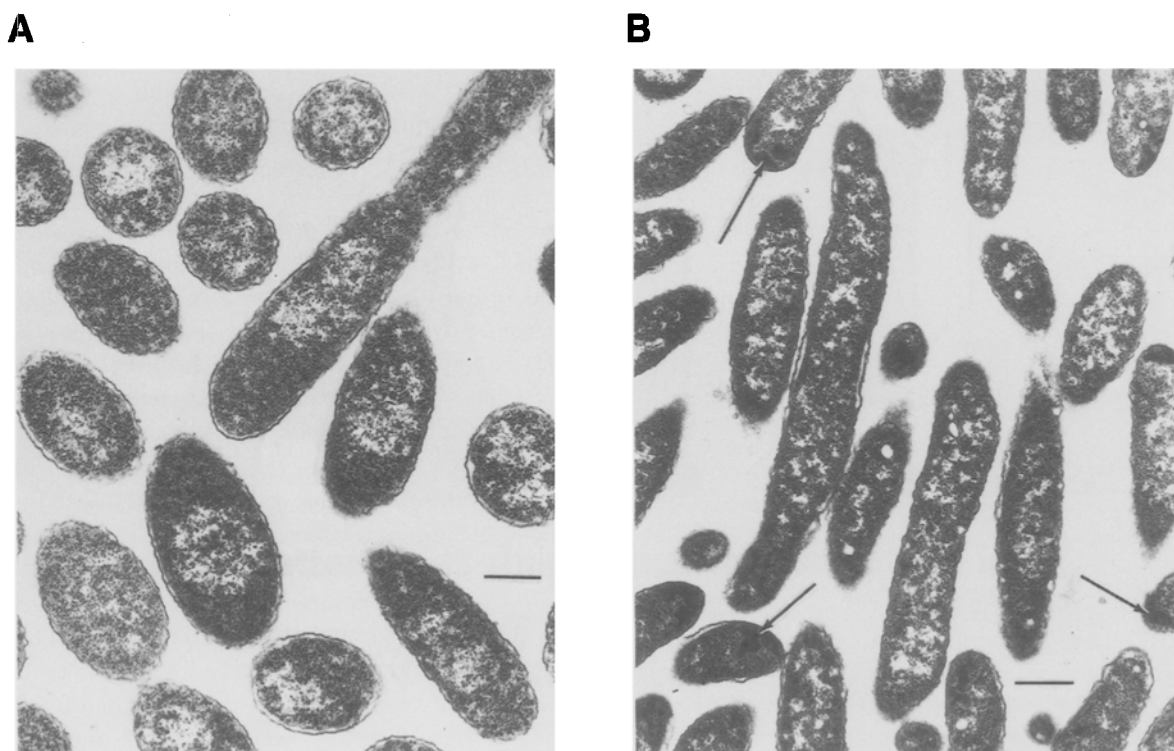

Fig. 7. Visualization of IL-4 aggregates within *E. coli* pKGT189-12/294: Aliquots of fermentations (42°C induction) described in Fig. 3 were removed at the designated times. Cells were harvested, then resuspended to original culture volume in 2.5% glutaraldehyde in 0.12 M cacodylate buffer, pH 7.0. The fixed cell pellets were then subjected to electron microscopy. A is cells at 30°C; B is cells after 4 h of induction at 42°C.

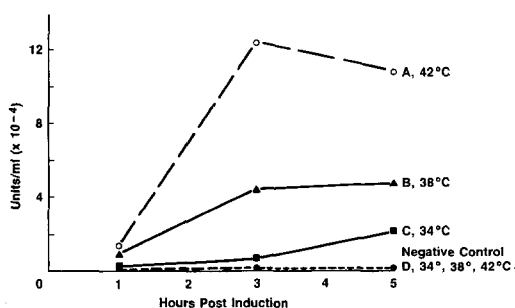

Fig. 8. Characterization of induction kinetics of pKGT189-12/*E. coli* 294 by bioassay in the presence of SDS: Aliquots of fermentations described in Fig. 3 were removed at the designated times. Cells were harvested and lysed with SDS, then diluted 1:50 in bioassay buffer as described in Materials and Methods. Samples from fermentations of pKGT189-12/*E. coli* 294 at 42°C (A), 38°C (B), 34°C (C), and fermentations of pKG25/*E. coli* 294 at 42°C, 38°C, or 34°C (D) were then assayed as described.

(pAH3/*E. coli* 294 and pKGT269-2/*E. coli* 294). The latter plasmid contained the same thermoinducible origin of replication as does pKGT189-12. Upon induction of this strain at 42°C, hIL-4 production could be detected on a western blot (Fig. 9). Induction was also achieved with 0.1 mM IPTG at 30°C. In both cases, the amount of processed hIL-4 was less than 1% of the total hIL-4 produced in the cytoplasmic strains. More unprocessed than processed hIL-4 was also detected indicating that we may have exceeded the capacity of these cells to export hIL-4.

Induction of pKGT269-2/*E. coli* 294 with IPTG at 30°C resulted in cessation of growth (generation time increases from 1–2 hours to about 24 hours) and a drop in oxygen consumption to 5% of the

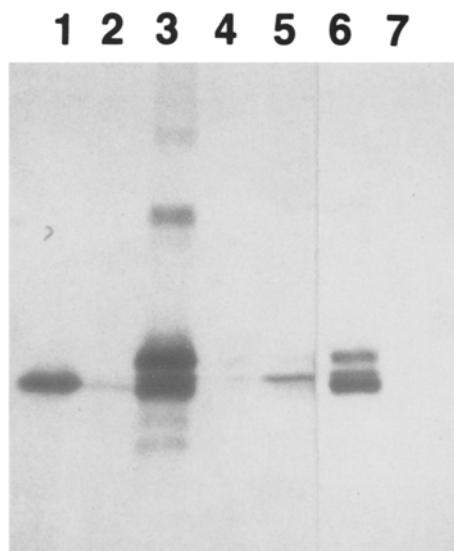

Fig. 9. Expression and localization of hIL-4 produced by a secretion cloning plasmid: pKGT269-2/*E. coli* 294 was grown in modified GC medium at 30°C. Upon reaching an optical density of ~ 1 at 660 nm, the fermentation temperature shifted to 42°C, and fermentation continued. Aliquots of the fermentation was removed, cells lysed by sonication, and the cell fractions analyzed by SDS polyacrylamide gel electrophoresis. The gels were then stained for hIL-4 protein immunologically. Lane 1, purified *E. coli* derived hIL-4; lane 2, soluble fraction for lysate of pKGT269-2/*E. coli* 294; lane 3, insoluble fraction from lysate of pKGT269-2/*E. coli* 294; lane 4, soluble fraction from lysate of negative control strain pKG86/*E. coli* 294, lane 5, insoluble fraction from lysate of pKG86/*E. coli* 294; lane 6, media fraction from pKGT269-2/*E. coli* 294 fermentation; lane 7, media fraction from control pKG86/*E. coli* 294 fermentation.

preinduction levels. Colony-forming units per ml remained constant for many hours indicating that no net cell death occurred. Growth cessation was correlated with about a ten-fold increase in the amount of hIL-4 within 1–2 hours.

Almost no soluble hIL-4 was found in pKGT269-2/294 after cell breakage (Fig. 9) and no hIL-4 could be released using an osmotic shock. Small amounts were released with a wash in 0.15 M NaCl containing 2.5 mM EDTA at pH 7.2 (data not shown). These results indicate that the hIL-4 in the periplasm was nearly as insoluble (or tightly bound) as IL-4 retained in the cytoplasm. The material from the periplasm was refolded in a manner similar to that described above and observed to have the

correct specific activity (data not shown). Sequence analysis of the periplasmically derived hIL-4 showed it to have the correct amino terminal sequence starting with histidine indicating that the processing of the signal sequence was faithful.

Release of Human IL-4 into the culture medium

The media after induction of pKGT269-2/294 was found to contain a considerable amount (30–50%) of the processed hIL-4 (Fig. 9). This hIL-4 was completely soluble on ultracentrifugation ($250\,000 \times g$, 30 min) and had a specific bioactivity expected for the native molecule.

Although we are not yet certain of the mechanism behind the release of hIL-4 into the medium, the total amount released was small (1–3 $\mu\text{g}/\text{ml}$ for a typical fermentation). The molecular weight of this hIL-4 containing complex is polydisperse and greater than 100 000 by gel filtration. Human IL-4 from the medium did not bind to a cation exchange resin (such as SP-sephadex) even though it had a *pI* of greater than 10. It has been shown that pure hIL-4 will form a tight, almost 1:1 molar complex with lipopolysaccharide from *E. coli* (C. Lunn, et al., submitted for publication) and it is possible that such a complex may be present in the medium. Human IL-4 was partially purified from the medium by trichloroacetic acid precipitation, followed by resuspension of the insoluble material in 6 M guanidine hydrochloride at pH 8. This solution was slowly analyzed against 10 mM Tris-HCl, pH 8. The hIL-4 present was bound to an SP-sephadex column and eluted with 1 M NaCl. As mentioned above, the specific bioactivity of this material was the same as the native molecule.

DISCUSSION

Current understanding of bacterial gene regulation has permitted construction of plasmids capable of production of large amounts of heterologous gene products in *E. coli*. With the addition of appropriate presequences (i.e., a signal peptide) the heterologous gene product can be directed outside the bacterial cytoplasm. Each mode of production

has its own strengths and weaknesses in the matters of yield, solubility and stability of the product. In this paper, we have investigated the production in *E. coli* of an extremely basic human protein, interleukin-4, using both cytoplasmic and extra-cytoplasmic expression systems.

In all cases in which the protein was expressed in the cytoplasm, expression of hIL-4 resulted in the accumulation of the gene product in insoluble protein aggregates. Alteration of the host strains harboring the hIL-4 encoding plasmid affected protein production, but was unable to produce soluble hIL-4. Manipulation of fermentation temperature was attempted to increase the amount of soluble heterologous protein [31] but no soluble hIL-4 was generated regardless of fermentation temperature used (23° to 42°C).

Electron microscopic characterization of many protein aggregates [32,33] show rounded structures localized to one pole of the bacterial cell. In contrast, visualization of the hIL-4 aggregate-containing bacteria by electron microscopy (Fig. 7) showed amorphous electron dense regions (presumably hIL-4) contiguous with the inner surface of the cytoplasmic membrane at numerous points around the periphery of the cell. The significance of this observation is not clear. It may be due to the highly basic hIL-4 ($pI > 10$) associating with acidic groups such as cytoplasmic membrane phospholipids. This argument has been used to rationalize the requirement of a basic amino terminus in *E. coli* signal peptides for efficient translocation [16].

Insoluble hIL-4 was successfully refolded by conventional procedures but was shown to be heterogeneous on ion-exchange chromatography (P. Trotta, personal communication). In addition, hIL-4 produced cytoplasmically contained a methionine at the amino terminus that is lacking in native IL-4. Both these factors led us to examine expression of hIL-4 in a secretory system.

The secretory expression of hIL-4 had a number of salient features. First, total hIL-4 production was low, i.e., 1–5% of the level of the cytoplasmic expression strains. Second, processing of the signal sequence was faithful leaving an N-terminal histidine (see Fig. 2), although the majority of the ex-

pressed hIL-4 was unprocessed. Third, cell-associated, processed hIL-4 was almost totally insoluble, although it could be refolded. Thus, the advantage of having a correct amino terminal sequence lacking the N-terminal methionine was nullified by the need to refold hIL-4, and was further complicated by the low yield.

Interestingly, with secretory expression a considerable percentage of the processed hIL-4 (30–50%) was not cell-associated but found in the medium. This material was completely soluble and had the expected specific bioactivity. The possibility exists that the processed hIL-4 in the media could be a result of cell lysis. This would be consistent with the finding that some unprocessed hIL-4 can also be detected in the medium (Fig. 9). However, we do not notice cell lysis upon induction commensurate with the fraction of IL-4 released, either by loss of optical density or by checking for the release of cytoplasmic enzymes. Therefore we believe that some of the processed hIL-4 has 'leaked' across the outer membrane into the medium.

We have been able to purify hIL-4 from the medium to a yield of about 1 mg/l which represents about 0.01% of total starting protein. This phenomenon of extracellular secretion has also been observed for HuGM-CSF in our laboratory (unpublished observation) and reported by at least one other group [30]. We view the purification of hIL-4 from the culture medium as a viable and interesting option. It could be important for production of a protein that is difficult to refold and/or is biologically active at a low dosage. More important, it is a starting point for constructing better producing strains. For example, one factor limiting the amount of leaked hIL-4 is probably the nearly bacteriostatic effect of IPTG induction. We can only speculate as to its cause. It must be at least partially hIL-4-dependent because the same effect is not seen when GM-SCF is secreted using a similar plasmid backbone, IPTG induction, and the same host strain [11]. Possibly the basic hIL-4 binds tightly to the secretory apparatus or forms membrane pores. If this growth-inhibiting effect could be reversed in a mutant, it might be possible to increase production.

ACKNOWLEDGEMENTS

We thank Dr. S. Jacobs and staff for carrying out the hIL-4 bioassays, Dr. P. Trotta and Dr. J. Eliason for critically reading the manuscript and Ms. Maria Carter for typing the manuscript.

REFERENCES

- 1 Bayer, M.E. 1979. The fusion sites between outer membrane and cytoplasmic membrane of bacteria: their role in membrane assembly and virus infection. In: Bacterial outer membrane: biogenesis and functions (Inouye, M., ed.), pp. 167–202, John Wiley and Sons, Inc., New York.
- 2 Better, M., C.P. Chang, R.R. Robinson and A.H. Horwitz. 1988. *Escherichia coli* secretion of an active chimeric antibody fragment. *Science*. 240: 1041–1043.
- 3 Bolivar, F. and K. Backman. 1979. Plasmids of *Escherichia coli* as cloning vectors. In: *Methods in Enzymology* 68, (Wu, R., ed.), pp. 245–267, Academic Press, New York.
- 4 Burnette, W.N., V.L. Mar, W. Cieplak, C.F. Morris, K.T. Kaljot, K.S. Marchitto, R.K. Sachdev, C. Loch and J.M. Keith. 1988. Direct expression of *Bordetella pertussis* toxin subunits to high levels in *Escherichia coli*. *Bio/Technology*. 6: 699–708.
- 5 Cabrillat, H., J.-P. Galizzi, O. Djossou, N. Arai, T. Yokota, K.-I. Arai and J. Banchereau. 1987. High affinity binding of human interleukin 4 to cell lines. *Biochem. Biophys. Res. Commun.* 149: 995–1001.
- 6 Campbell, J.L., C.C. Richardson and F.W. Studier. 1978. Genetic recombination and complementation between bacteriophage T7 and cloned fragments of T7 DNA. *Proc. Natl. Acad. Sci. U.S.A.* 75: 2276–2280.
- 7 Crawford, R.M., D.S. Finbloom, J. O'Hara, W.E. Paul and M.S. Meltzer. 1987. B cell stimulatory factor-1 (Interleukin 4) activities macrophages for increased tumoricidal activity and expression of Ia antigens. *J. Immunol.* 139: 135–141.
- 8 DeFrance, T., B. VanBervliet, J.-P. Aubry, Y. Takebe, N. Arai, A. Miyajima, T. Yokota, F. Lee, K.-I. Arai, J.E. deVries and J. Banchereau. 1987. B cell growth-promoting activity of recombinant human interleukin 4. *J. Immunol.* 139: 1135–1141.
- 9 Georgiuo, G., J.H. Telford, M.L. Shuler and D.B. Wilson. 1986. Localization of inclusion bodies in *Escherichia coli* overproducing beta-lactamase and alkaline phosphatase. *Appl. and Environmental Microbiol.* 4: 1157–1161.
- 10 Ghayeb, J., H. Kimura, M. Takahara, H. Hsiung, Y. Masui and M. Inouye. 1984. Secretion cloning vectors in *E. coli*. *EMBO J.* 3: 2437–2442.
- 11 Greenberg, R., D. Lundell, Y. Alroy, S. Bonitz, R. Condon, J. Fossetta, B. Frommer, K. Gewain, M. Katz, P. Leibowitz, S. Narula, R. Kastelein and A. Van Kimmenade. 1988. Expression of biologically active, mature human granulocyte-macrophage colony stimulating factor with an *E. coli* secretory expression system. *Current Microbiology*. 17: 321–332.
- 12 Hakkaart, M.J.J., E. Veltkamp and H.J.J. Nijkamp. 1981. Protein H encoded by plasmid Clo DF13 involved in lysis of the bacterial host II. Functions and regulations of synthesis of the gene H product. *Mol. Gen. Genet.* 183: 326–332.
- 13 Hobot, J.A., E. Carlemalm, W. Villinger and E. Kellenberger. 1984. Periplasmic gel: New concept resulting from the reinvestigation of bacterial cell envelope ultrastructure by new methods. *J. Bacteriol.* 160: 143–152.
- 14 Howard-Flanders, P., E. Simson and L. Theriot. 1964. A locus that controls filament formation and sensitivity to radiation in *Escherichia coli* K12. *Genetics*. 49: 237–246.
- 15 Hudak, S.A., S.O. Gollnick, D.H. Conrad and M.R. Kehry. 1987. Murine B-cell stimulatory factor 1 (interleukin 4) increases expression of the Fc receptor for IgE on mouse B cells. *Proc. Natl. Acad. Sci. U.S.A.* 84: 4606–4610.
- 16 Inouye, S., X. Soberon, T. Franceschini, K. Nakamura, K. Itakura and M. Inouye. 1982. Role of positive charge on the amino-terminal region of the signal peptide in protein secretion across the membrane. *Proc. Natl. Acad. Sci. U.S.A.* 79: 3438–3441.
- 17 Itoh, S., T. Mizukami, T. Matsumoto, A. Nishi, T. Saito, T. Oka, A. Furuya, C. Takaoka and T. Taniguchi. 1984. Efficient expression in *Escherichia coli* of a mature and a modified human interferon- β . *DNA*. 3: 157–165.
- 18 King, J., C. Haase and M. Yu. 1987. Temperature-sensitive mutations affecting kinetic steps in protein-folding pathways. In: *Protein Engineering*. (Oxender, D.L. and C.F. Fox, eds.), pp. 109–121, Alan R. Liss, New York.
- 19 Laemmli, U.K. 1970. Cleavage of structural proteins during the assembly of the head of bacteriophage T4. *Nature*. 227: 680–685.
- 20 Lowenthal, J.W., B.E. Castle, J. Christiansen, J. Schreurs, D. Rennick, N. Arai, P. Hoy, Y. Takebe and M. Howard. 1988. Expression of high affinity receptors for murine interleukin 4 (BSF-1) on hemopoietic and nonhemopoietic cells. *J. Immunol.* 140: 456–464.
- 21 Lunn, C.A., M. Takahara and M. Inouye. 1986. Secretion cloning vectors for guiding the localization of proteins in vivo. *Current Topics Microbiol. and Immunol.* 125: 59–74.
- 22 Maniatis, T., E.F. Fritsch and J. Sambrook. 1982. *Molecular Cloning, A Laboratory Manual*. pp. 88–96.
- 23 Marks, C.B., M. Vasser, P. Ng, W. Henzel and S. Anderson. 1986. Production of native, correctly folded bovine pancreatic trypsin inhibitor by *Escherichia coli*. *J. Biol. Chem.* 261: 7115–7118.
- 24 Mosmann, T.R., M.W. Bond, R.L. Coffman, J. O'Hara and W.E. Paul. 1986. T-cell and mast cell lines respond to B-cell stimulatory factor 1. *Proc. Natl. Acad. Sci. U.S.A.* 83: 5654–5638.
- 25 Mosmann, T.R., T. Yokota, R. Kastelein, S.M. Zurawski, N. Arai and Y. Takebe. 1987. Species-specificity of T cell stimulating activities of IL-2 and BSF-1 (IL-4): Comparison

- of normal and recombinant, mouse and Human IL-2 and BSF-1 (IL-4) *J. Immunol.* 138: 1813–1816.
- 26 Mosmann, T.R., J.S. Abrams, K.-I. Arai, N. Arai, M.W. Bond, F.D. Lee, A. Miyajima, S. Miyatake, D.M. Rennick, J. Schreurs, C.A. Smith, Y. Takebe, T. Yokata, G. Zurawski and S.M. Zurawski. 1987. Mouse interleukin-3 recombinant cDNA cloning expression, and characterization. In: *Recombinant Lymphokines and Their Receptors 11*, (Gillis, S. ed.), pp. 217–240, Marcel Dekker, Inc., New York.
 - 27 Mulford, C.A. and M.J. Osborn. 1983. An intermediate step in translocation of lipopolysaccharide to the outer membrane of *Salmonella typhimurium*. *Proc. Natl. Acad. Sci. U.S.A.* 80: 1159–1163.
 - 28 Paul, D., R. VanFrank, W. Muth, J. Ross and D. Williams. 1983. Immunocytochemical demonstration of human proinsulin chimeric polypeptide within cytoplasmic inclusion bodies of *Escherichia coli*. *Euro. J. Cell Biol.* 31: 171–174.
 - 29 Prentki, P., F. Karch, S. Iida and J. Meyer. 1981. The plasmid cloning vector pBR325 contains a 482 base-pair-long inverted duplication. *Gene.* 14: 289–299.
 - 30 Sakaguchi, M., K. Yamanishi, Y. Ohmoto, T. Kamogashira and Y. Hirai. 1988. Extracellular secretion of human granulocyte-macrophage colony-stimulating factor in *E. coli*. *Agric. Biol. Chem.* 52: (10) 2669–2672.
 - 31 Schein, C.H. and M.H.M. Noteborn. 1988. Formation of soluble recombinant proteins in *Escherichia coli* is favored by lower growth temperature. *Bio/Technology.* 6: 291–294.
 - 32 Schoemaker, J., A. Brasnett and F. Marston. 1985. Examination of calf prochymosin accumulation in *Escherichia coli*: Disulphide linkages are a structural component of prochymosin-containing inclusion bodies. *EMBO J.* 4: 775–786.
 - 33 Schoner, R.G., E.F. Lee, and B.E. Schoner. 1985. The isolation and purification of protein granules from *E. coli* cells overproducing bovine growth hormone. *Bio/Technology.* 3: 151–154.
 - 34 Towbin, H., T. Staehelin and J. Gordon. 1979. Electrophoretic transfer of proteins from polyacrylamide gel to nitrocellulose sheets: procedure and some applications. *Proc. Natl. Acad. Sci. U.S.A.* 76: 4350–4354.
 - 35 Van Kimmenade, A., M.W. Bond, J.H. Schumacher, C. Laquoi and R.A. Kastelein. 1988. Expression, renaturation and purification of recombinant human interleukin 4 from *Escherichia coli*. *Eur. J. Biochem.* 173: 109–114.
 - 36 Yokota, T., T. Otsuka, T. Mosmann, J. Banchereau, T. DeFrance, D. Blanchard, J.E. DeVries, F. Lee and K.-I. Arai. 1986. Isolation and characterization of a human interleukin cDNA clone, homologous to mouse B-cell stimulatory factor 1, that expresses B-cell- and T-cell-stimulating activities. *Proc. Natl. Acad. Sci. U.S.A.* 83: 5894–5898.
 - 37 Zlotnik, A., J. Ransom, G. Frank, M. Fischer and M. Howard. 1987. Interleukin 4 is a growth factor for activated thymocytes: Possible role in T-cell ontogeny. *Proc. Natl. Acad. Sci. U.S.A.* 84: 3856–3860.
 - 38 Zoller, M.J. and M. Smit. 1983. Oligonucleotide-directed mutagenesis of DNA fragments cloned into M13 vectors. Part B: In: *Methods in Enzymology 100*. (Wu, R., L. Grossman and K. Moldave, eds.), pp. 468–500, Academic Press, New York.